

STOCKAGE HUILES USÉES

CUVES RECUP CUBE

- Cuve double paroi PE conforme NF EN 13341
 - Jauge de niveau à cadran
 - Témoin optique de fuite
 - Ouverture d'inspection DN150 avec couvercle vissant
 - Tube de vidange 2" avec raccord pompier et son bouchon
 - Événement 2"
 - Bandages de renfort acier galvanisé
 - Passage de fourches pour manutention à vide
- Collecteur en forme d'entonnoir avec grille de filtration des particules
- Égouttoir



Cuve RECUP Cube Outdoor

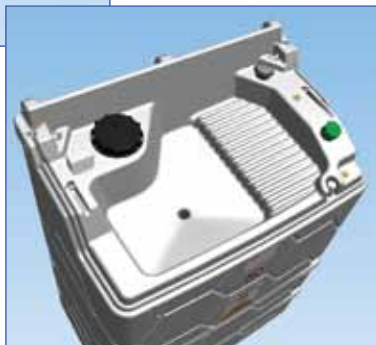

Cuve RECUP Cube Outdoor



Kit complet capot



Éclairage LED

CUVES RECUP CUBE

Désignation		Dimensions en cm (L x l x h)	Poids en kg	Référence
Cuve RECUP Cube Indoor 1000 litres		120 x 80 x 174	125	10477
Cuve RECUP Cube Indoor 1500 litres		120 x 115 x 174	155	10478
Cuve RECUP Cube Indoor 2500 litres		120 x 180 x 174	210	10479
Cuve RECUP Cube Outdoor 1000 litres		120 x 80 x 180	140	10480
Cuve RECUP Cube Outdoor 1500 litres		120 x 115 x 180	170	10481
Cuve RECUP Cube Outdoor 2500 litres		120 x 180 x 180	225	10482

ACCESSOIRES

Désignation	Poids en kg	Référence
Kit complet capot orange pour stations Cube	10	10324
Dérouleur papier absorbant pour cuve RECUP Cube		10325
Éclairage LED pour capot stations CUBE		10378